

# Absolute encoders - SSI

Blind / through hollow shaft or cone shaft (1:10)

ST and MT 20 bit each / Speed switch

## HMG10 - SSI



HMG 10 - picture similar

### Technical data - electrical ratings

Voltage supply	4.75...30 VDC
Short-circuit proof	Yes
Consumption w/o load	≤100 mA (SSI)
Initializing time	≤500 ms after power on
Interface	SSI
Function	Multiturn
Steps per turn	1048576 / 20 bit
Number of turns	1048576 / 20 bit
Additional outputs	Square-wave HTL/TTL (RS422)
Sensing method	Magnetic
Code	Gray (default) or binary
Code sequence	CW/CCW programmable CW default
Input signals	SSI clock, PRESET, rotating direction
Interference immunity	EN 61000-6-2
Emitted interference	EN 61000-6-3
Diagnostic function	Self-diagnosis
Status indicator	4 LEDs in device back side
Approvals	CE, UL approval / E256710

### Technical data - electrical ratings (speed switches)

Interface	RS485
Switching accuracy	±2 % (or Digit)
Switching outputs	1 output (Open-Collector or Solid State Relay)
Output switching capacity	30 VDC; ≤100 mA
Switching delay time	≤20 ms

### Features

- Interface SSI
- Magnetic sensing method
- Resolution: singleturn 20 bit, multiturn 20 bit
- Function display via LEDs
- Multiturn sensing with Energy Harvesting technologie, without gear or battery
- Two hybrid bearings, one at each end
- Special protection against corrosion C5-M

### Optional

- Integrated speed switch, programmable
- Additional outputs incremental with zero pulse

### Technical data - mechanical design

Size (flange)	ø105 mm
Flange	Support plate, 360° freely positionable
Protection DIN EN 60529	IP 66/IP 67
Operating speed	≤12000 rpm
Range of switching speed	±2...12000 rpm, default 12000 rpm
Operating torque typ.	10 Ncm
Rotor moment of inertia	950 gcm <sup>2</sup>
Admitted shaft load	≤450 N axial ≤650 N radial
Materials	Housing: aluminium alloy Shaft: stainless steel
Operating temperature	-40...+85 °C
Relative humidity	95 % non-condensing
Resistance	IEC 60068-2-6 Vibration 30 g, 10-2000 Hz IEC 60068-2-27 Shock 400 g, 1 ms
Corrosion protection	IEC 60068-2-52 Salt mist Complies to ISO 12944-5:1998 Protective paint systems (C5-M)
Weight approx.	1.6 kg (depending on version)
Connection	Terminal box Flange connector M23
<b>HMG10-B - SSI</b>	
Shaft type	ø16...20 mm (blind hollow shaft) ø17 mm (cone shaft 1:10)
<b>HMG10-T - SSI</b>	
Shaft type	ø16...20 mm (through hollow shaft)

# Absolute encoders - SSI

## Blind / through hollow shaft or cone shaft (1:10)

### ST and MT 20 bit each / Speed switch

**HMG10 - SSI**

**Part number**

Encoder with blind hollow shaft / cone shaft

HMG10   -B H .                         .A

Additional output 2\*  
0 Without  
See also table "Additional output 2"

Additional output 1  
0 Without  
See also table "Additional output 1"

Resolution speed  
0 Without  
See also table "Resolution speed"

Resolution multiturn  
2 12 bit  
6 16 bit  
See also table "Resolution multiturn"

Resolution singleturn  
3 13 bit  
See also table "Resolution singleturn"

Voltage supply / interface  
UG 4,75...30 VDC, SSI Gray  
UB 4.75...30 VDC, SSI binary

Connection  
2 1x terminal box with cable gland M20, radial  
G 1x flange connector M23, radial, 17-pin, male, CW  
M 2x terminal box with cable gland M20, radial  
S 2x flange connector M23, radial (1x 17-pin, male, CW + 1x 12-pin, male, CW)

Shaft diameter  
6 ø16 mm, central screw  
7 ø17 mm cone 1:10, central screw  
Z ø20 mm, central screw

Protection  
D IP 66 and IP 67, optimized for dusty environments  
L IP 66 and IP 67, optimized for oily and wet environments

Flange  
H Support for torque arm, shaft insulation hybrid bearing

Speed switch / Programming  
Without  
D With speed switch \*  
(Standard: Open Collector, Solid State Relais on request)

\* Only for connection M or S

10/8/2016 Subject to modification in technic and design. Errors and omissions excepted.

# Absolute encoders - SSI

Blind / through hollow shaft or cone shaft (1:10)  
ST and MT 20 bit each / Speed switch

## HMG10 - SSI

Part number										
Encoder with through hollow shaft										
HMG10		-T	H	.						.A
										<p><u>Additional output 2*</u></p> <p>0 Without See also table "Additional output 2"</p> <p><u>Additional output 1</u></p> <p>0 Without See also table "Additional output 1"</p> <p><u>Resolution speed</u></p> <p>0 Without See also table "Resolution speed"</p> <p><u>Resolution multiturm</u></p> <p>2 12 bit 6 16 bit See also table "Resolution multiturm"</p> <p><u>Resolution singleturm</u></p> <p>3 13 bit See also table "Resolution singleturm"</p> <p><u>Voltage supply / interface</u></p> <p>UG 4.75...30 VDC, SSI Gray UB 4.75...30 VDC, SSI binary</p> <p><u>Connection</u></p> <p>2 1x terminal box with cable gland M20, radial G 1x flange connector M23, radial, 17-pin, male, CW M 2x terminal box with cable gland M20, radial S 2x flange connector M23, radial (1x 17-pin, male, CW + 1x 12-pin, male, CW)</p> <p><u>Shaft diameter</u></p> <p>C ø16 mm, clamping ring on drive side F ø20 mm, clamping ring on drive side P ø16 mm, clamping ring on drive side with keyway</p> <p><u>Protection</u></p> <p>D IP 66 and IP 67, optimized for dusty environments L IP 66 and IP 67, optimized for oily and wet environments</p> <p><u>Flange</u></p> <p>H Support for torque arm, shaft insulation hybrid bearing</p> <p><u>Speed switch / Programming</u></p> <p>Without</p> <p>D With speed switch * (Standard: Open Collector, Solid State Relais on request)</p>

\* Only for connection M or S

# Absolute encoders - SSI

## Blind / through hollow shaft or cone shaft (1:10)

### ST and MT 20 bit each / Speed switch

## HMG10 - SSI

### Part number - tables

#### Resolution singleturn

0 (Without)	2 (12 bit)	5 (15 bit)	8 (18 bit)
A (10 bit)	3 (13 bit)	6 (16 bit)	9 (19 bit)
1 (11 bit)	4 (14 bit)	7 (17 bit)	B (20 bit)

#### Resolution multiturn

0 (Without)	2 (12 bit)	5 (15 bit)	8 (18 bit)
A (10 bit)	3 (13 bit)	6 (16 bit)	9 (19 bit)
1 (11 bit)	4 (14 bit)	7 (17 bit)	B (20 bit)

#### Resolution speed

0 (Without)	5 (15 bit, ±6000 rpm)
A (10 bit, ±6000 rpm)	6 (16 bit, ±6000 rpm)
1 (11 bit, ±6000 rpm)	7 (17 bit, ±6000 rpm)
2 (12 bit, ±6000 rpm)	8 (18 bit, ±6000 rpm)
3 (13 bit, ±6000 rpm)	9 (19 bit, ±6000 rpm)
4 (14 bit, ±6000 rpm)	B (20 bit, ±6000 rpm)

#### Additional output 1

0 (Without)
Q (8192 ppr TTL/HTL push-pull (Vin=Vout), 4 channels)
P (8192 ppr TTL (RS422), 4 channels)
G (5000 ppr TTL/HTL push-pull (Vin=Vout), 4 channels)
H (5000 ppr TTL (RS422), 4 channels)
K (4096 ppr TTL/HTL push-pull (Vin=Vout), 4 channels)
J (4096 ppr TTL (RS422), 4 channels)
7 (3072 ppr TTL/HTL push-pull (Vin=Vout), 4 channels)
8 (3072 ppr TTL (RS422), 4 channels)
9 (2048 ppr TTL/HTL push-pull (Vin=Vout), 4 channels)
4 (2048 ppr TTL (RS422), 4 channels)
5 (1024 ppr TTL/HTL push-pull (Vin=Vout), 4 channels)
6 (1024 ppr TTL (RS422), 4 channels)
1 (512 ppr TTL/HTL push-pull (Vin=Vout), 4 channels)
2 (512 ppr TTL (RS422), 4 channels)

#### Additional output 2\*

0 (Without)
Q (8192 ppr TTL/HTL push-pull (Vin=Vout), 6 channels)
P (8192 ppr TTL (RS422), 6 channels)
G (5000 ppr TTL/HTL push-pull (Vin=Vout), 6 channels)
H (5000 ppr TTL (RS422), 6 channels)
K (4096 ppr TTL/HTL push-pull (Vin=Vout), 6 channels)
J (4096 ppr TTL (RS422), 6 channels)
7 (3072 ppr TTL/HTL push-pull (Vin=Vout), 6 channels)
8 (3072 ppr TTL (RS422), 6 channels)
9 (2048 ppr TTL/HTL push-pull (Vin=Vout), 6 channels)
4 (2048 ppr TTL (RS422), 6 channels)
5 (1024 ppr TTL/HTL push-pull (Vin=Vout), 6 channels)
6 (1024 ppr TTL (RS422), 6 channels)
1 (512 ppr TTL/HTL push-pull (Vin=Vout), 6 channels)
2 (512 ppr TTL (RS422), 6 channels)

\* Only for connection M or S

# Absolute encoders - SSI

Blind / through hollow shaft or cone shaft (1:10)

ST and MT 20 bit each / Speed switch

## HMG10 - SSI

### Terminal significance

+UB	Voltage supply
⊥	Ground
A+	Channel A+
A-	Channel A- (channel A+ inverted)
B+	Channel B+
B-	Channel B- (channel B+ inverted)
R+	Zero pulse (reference signal)
R-	Zero pulse inverted
nE+	System OK+ / error output
nE-	System OK- / error output inverted
PRE	PRESET/RESET
DIR	Rotating direction
SP+ <sup>2)</sup>	DSL_OUT1 / speed switch (Open-Collector or Solid State Relay)
SP- <sup>2)</sup>	DSL_OUT2 / speed switch (0 V or Solid State Relay)
SA <sup>2)</sup>	RS485+ / programming interface
SB <sup>2)</sup>	RS485- / programming interface
D+	SSI DATA+
D-	SSI DATA-
C+	SSI CLOCK+
C-	SSI CLOCK-
dnu	Do not use

### Terminal assignment terminal box

View A<sup>1)</sup> - SSI

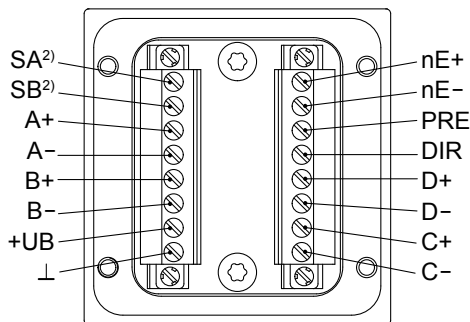

View B<sup>1)</sup> - Speed switch/incremental

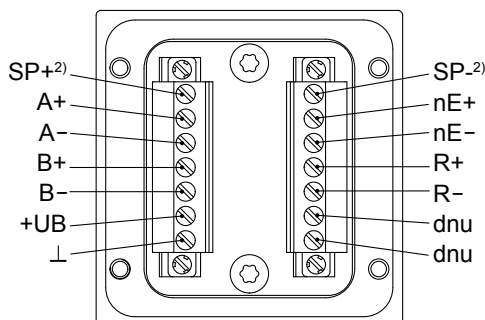

<sup>1)</sup> See dimensions

<sup>2)</sup> Do not use at version without speed switch

### Terminal assignment flange connectors

View C<sup>1)</sup> - SSI, flange connector M23 (male, 17-pin)

1	nE-
2	DIR
3	SB <sup>2)</sup>
4	nE+
5	PRE
6	SA <sup>2)</sup>
7	+UB
8	C+
9	C-
10	⊥
11	Internal shield
12	B+
13	B-
14	D+
15	A+
16	A-
17	D-

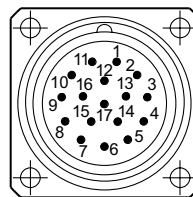

Clockwise (CW)

View C<sup>1)</sup> - Speed switch/incremental, flange connector M23 (male, 12-pin)

1	B-
2	nE-
3	R+
4	R-
5	A+
6	A-
7	SP+ <sup>2)</sup>
8	B+
9	SP- <sup>2)</sup>
10	⊥
11	nE+
12	+UB

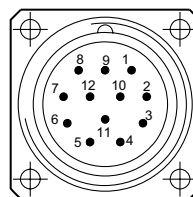

Clockwise (CW)

# Absolute encoders - SSI

## Blind / through hollow shaft or cone shaft (1:10)

### ST and MT 20 bit each / Speed switch

HMG10 - SSI

#### Data transfer

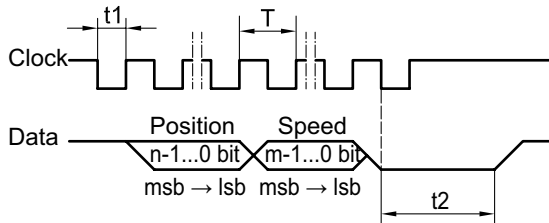

Clock frequency	100 kHz...2 MHz
Period (T)	0,5...10 $\mu$ s
Time lag (t1)	0,25...5 $\mu$ s
Monoflop time (t2)	20 $\mu$ s (internal)
n, m	Number of bits

For continuous clocking, the SSI word is transmitted only once followed by zero values (no ring register operation).

#### Incremental - Output signals

Version with additional incremental output at positive rotating direction

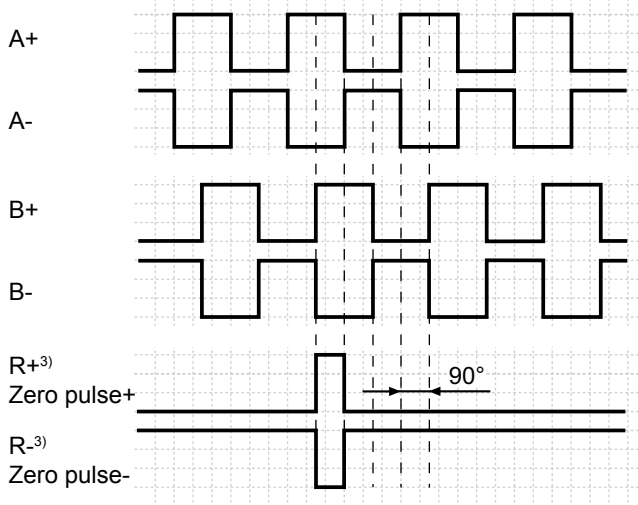

#### Speed switch - Switching characteristics

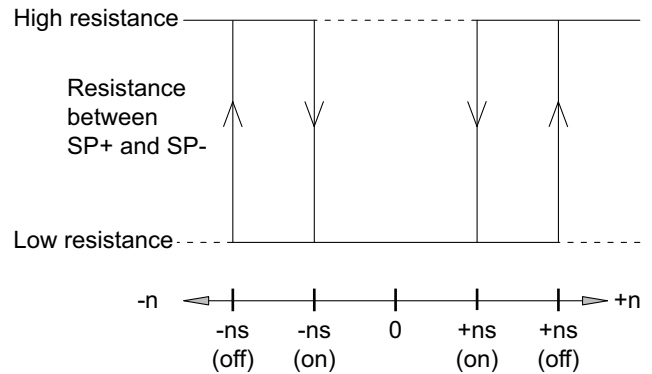

- n = Speed
- +ns (on) = Activation speed at shaft rotation in positive rotating direction<sup>1)</sup>.
- +ns (off) = Deactivation speed at shaft rotation in positive rotating direction<sup>1)</sup>.
- ns (on) = Activation speed at shaft rotation in negative rotating direction<sup>1)</sup>.
- ns (off) = Deactivation at shaft rotation in negative rotating direction<sup>1)</sup>.

<sup>1)</sup> See dimensions

<sup>3)</sup> Only additional output 2

# Absolute encoders - SSI

Blind / through hollow shaft or cone shaft (1:10)

ST and MT 20 bit each / Speed switch

## HMG10 - SSI

---

### Accessories

#### Connectors and cables

HEK 8	Sensor cable for encoders
HEK 17	Sensor cable for encoders
11068577	Mating connector M23, solder version, 12-pin, CCW
11068551	Mating connector M23, solder version, 17-pin, CCW

#### Mounting accessories

11043628	Torque arm M6, length 67-70 mm
11004078	Torque arm M6, length 120-130 mm ( $\geq 71$ mm)
11002915	Torque arm M6, length 425-460 mm ( $\geq 131$ mm)
11054917	Insulated torque arm M6, length 67-70 mm
11072795	Insulated torque arm M6, length 120-130 mm ( $\geq 71$ mm)
11082677	Insulated torque arm M6, length 425-460 mm ( $\geq 131$ mm)
11077197	Mounting kit for torque arm size M6 and earthing strap
11077087	Mounting and dismounting set

# Absolute encoders - SSI

Blind / through hollow shaft or cone shaft (1:10)  
ST and MT 20 bit each / Speed switch

HMG10 - SSI

## Dimensions

### Blind hollow shaft and cone shaft with radial terminal boxes

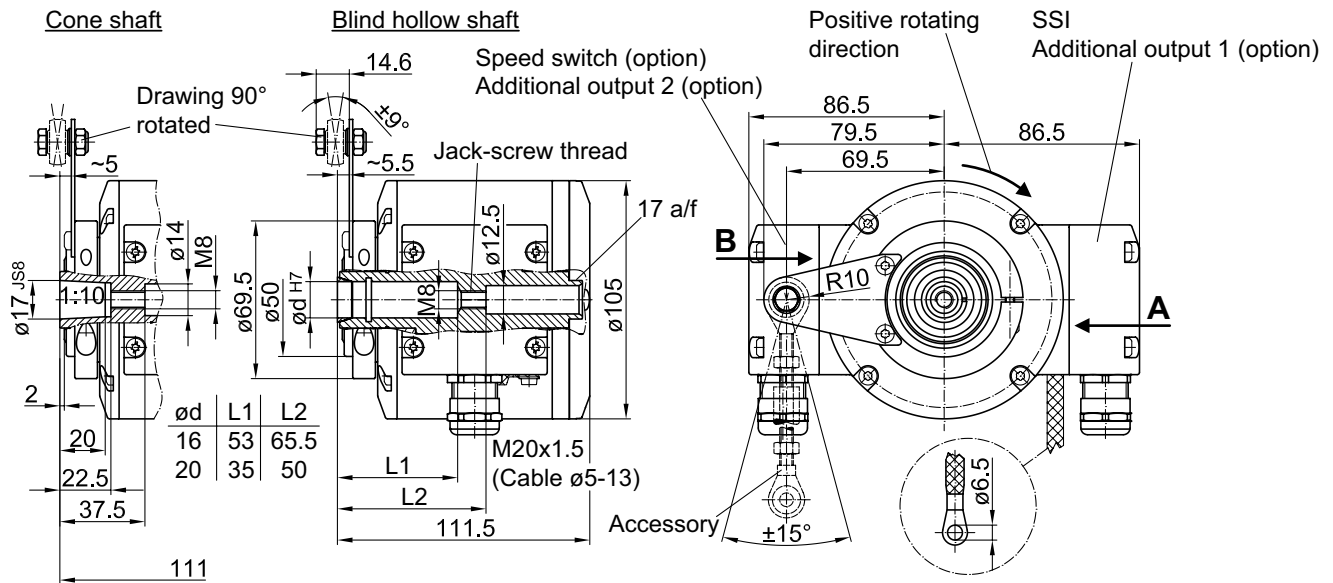

### Blind hollow shaft and cone shaft with radial flange connectors M23

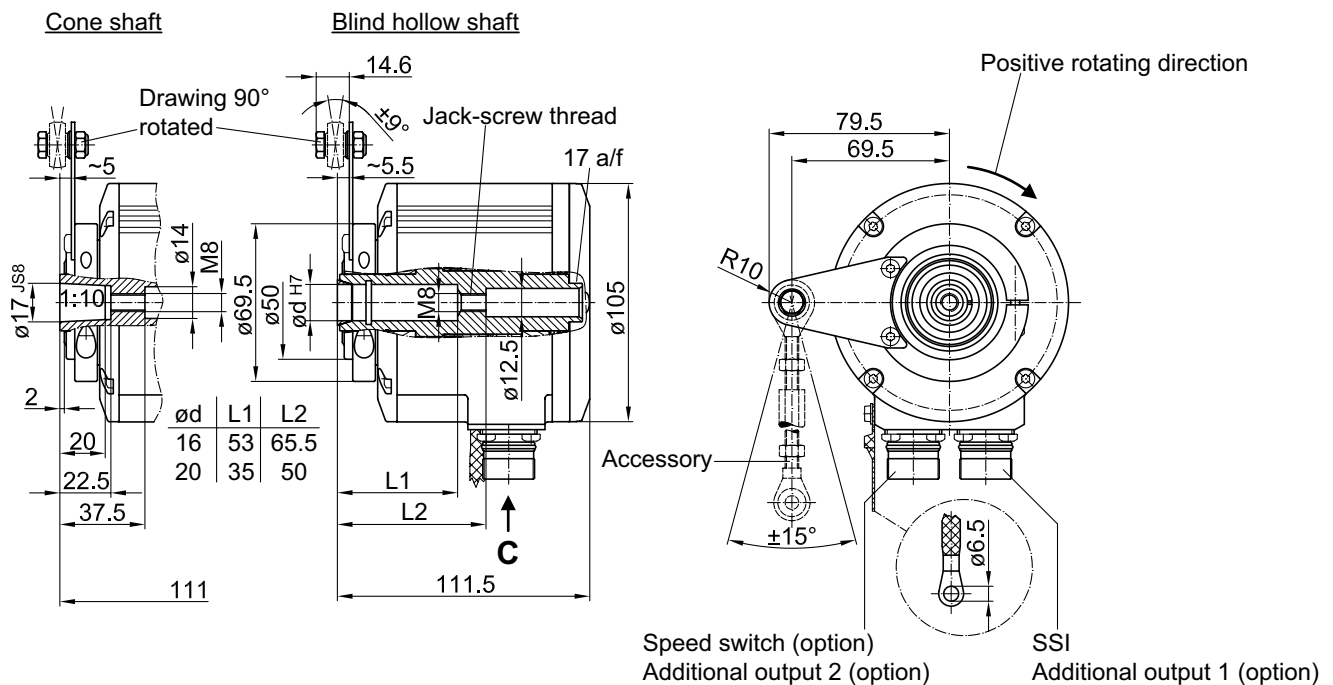



# Absolute encoders - SSI

Blind / through hollow shaft or cone shaft (1:10)

ST and MT 20 bit each / Speed switch

## HMG10 - SSI

### Dimensions

#### Through hollow shaft with radial terminal boxes

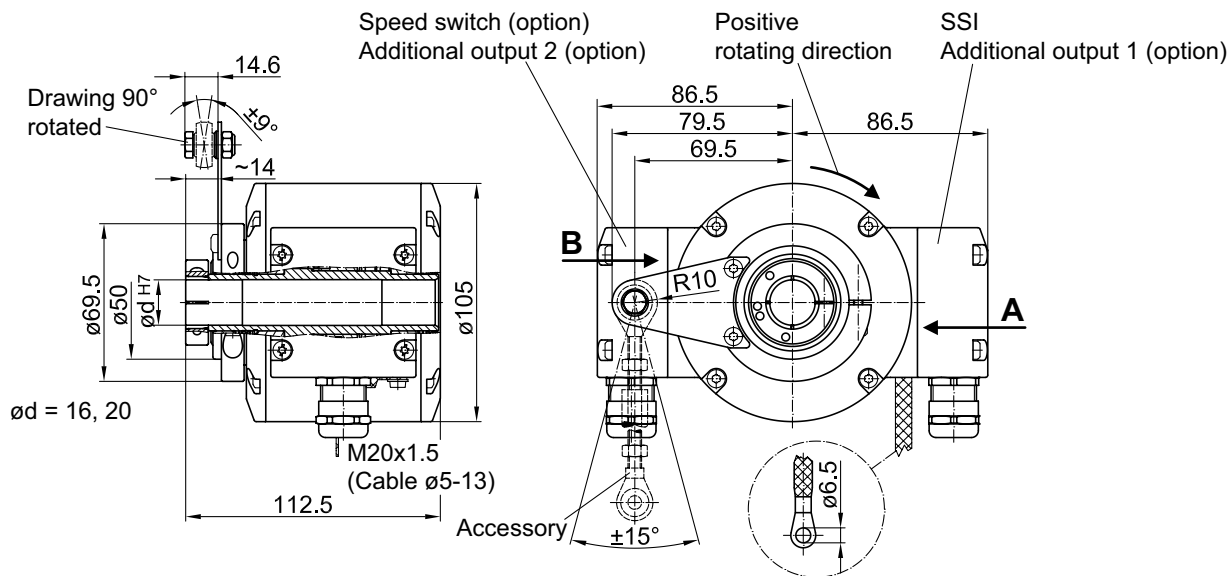

#### Through hollow shaft with radial flange connectors M23

